

AMTEC SUPPORT GRIPS

STANDARD, HEAVY DUTY & CONDUIT GRIPS

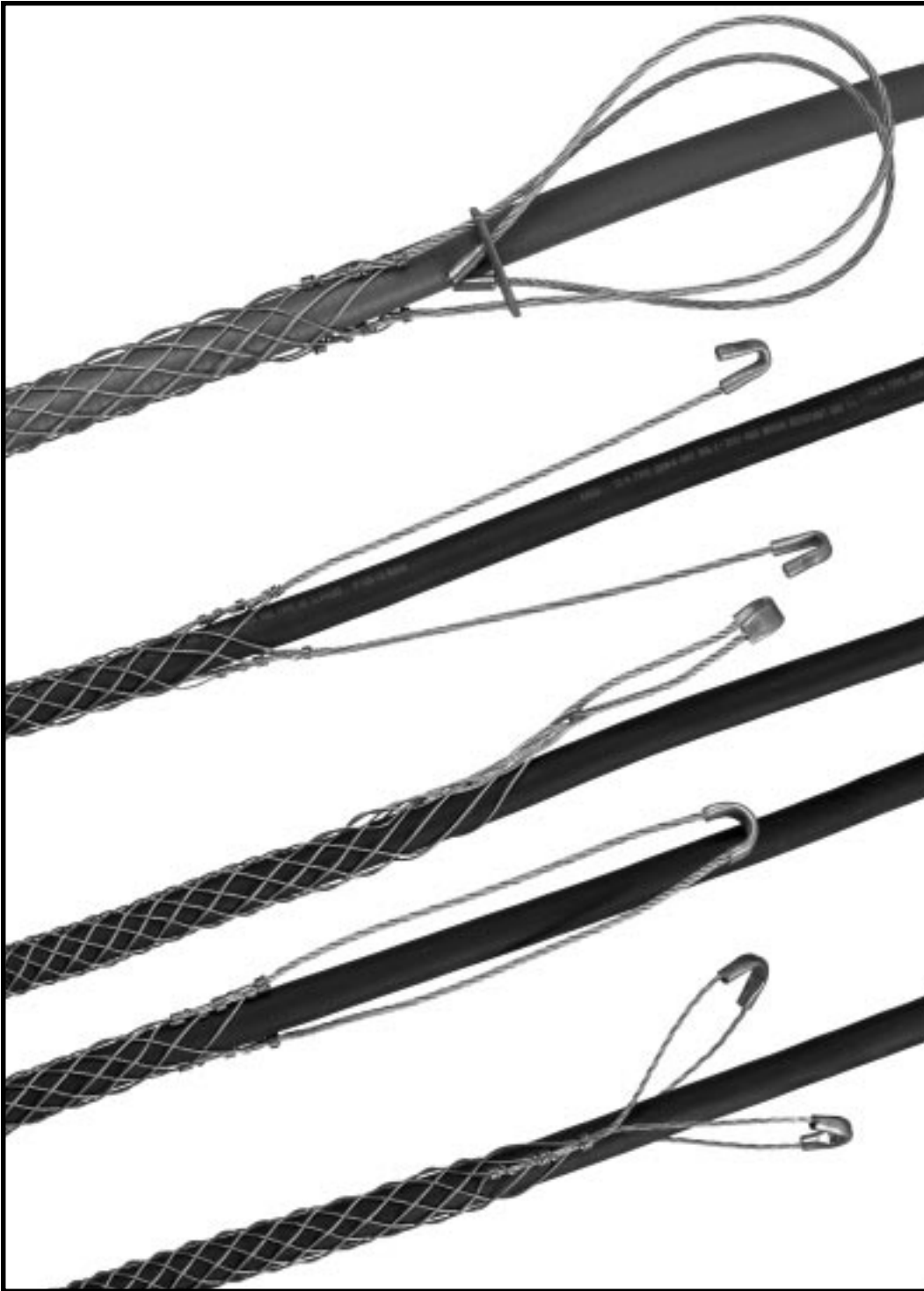

- *DESIGNED TO HOLD THE WEIGHT FOR ELECTRICAL CABLE AS IT HANGS IN VERTICAL, SLOPING OR HORIZONTAL POSITIONS.*
- *EASILY INSTALLED AND REMOVED USING NO SPECIAL SKILLS OR TOOLS.*
- *PERMITS CABLE TO EXPAND AND CONTRACT WITHOUT LOSS OF HOLDING ACTION.*
- *INSTANTLY RELOCATED OR REPOSITIONED WHICH SAVES TIME AND LABOR.*
- *CONFORMS TO SHAPE OF CABLE OR OBJECT BEING SUPPORTED.*
- *USED ON ANY APPLICATION SUCH AS SUPPORTING CABLE, METAL RODS, HOSE AND TUBING. SPECIFIC APPLICATIONS INCLUDE BUILDINGS, POLES, EXCAVATIONS, MINE SHAFTS, TOWERS, ELEVATORS, POTHEADS, TERMINATORS OR OTHER STRUCTURES.*

AMTEC SUPPORT GRIPS

FOR SELECTING THE CORRECT SUPPORT GRIP:

- REFER TO THE LIST BELOW TO DETERMINE THE GRIP STYLE BEST SUITED FOR YOUR APPLICATION.
- DETERMINE YOUR CABLE OUTSIDE DIAMETER.
- FIND THE GRIP SIZE THAT ENCOMPASSES YOUR CABLE DIAMETER.
- WHENEVER POSSIBLE, USE A CLOSED MESH THAT ASSEMBLES OVER THE CABLE END. IF THE CABLE END IS NOT AVAILABLE, USE A SPLIT MESH.
- SELECT AN EYE STYLE THAT SUITS YOUR NEEDS.
- REFER TO PG "B" FOR WORK LOADS AND SAFETY FACTORS.

GRIP STYLES & APPLICATION:

- **CLOSED MESH:**
PERMANENT SUPPORT, CABLE END AVAILABLE.
- **SPLIT LACE CLOSING:**
PERMANENT SUPPORT, CABLE END UNAVAILABLE.
- **SPLIT ROD CLOSING:**
TEMPORARY SUPPORT, CABLE END UNAVAILABLE.
- **STANDARD SUPPORT GRIPS:**
SUPPORT VERTICAL RUNS TO 99 FT. & LOADS TO 600 LBS.
- **HEAVY DUTY SUPPORT GRIPS:**
SUPPORT VERTICAL RUNS OVER 100 FT. AND LOADS OVER 600 LBS.
- **SERVICE DROP GRIPS:**
SUPPORT LIGHT DUTY CABLE, FIBER OPTIC CABLE & SERVICE ENTRANCE CABLE.
- **CONDUIT RISER GRIPS:**
SUPPORT CABLE IN RIGID CONDUIT.

AMTEC SUPPORT GRIPS

AMTEC SUPPORT GRIPS ARE MADE OF STRANDED TINNED BRONZE WIRE. STAINLESS STEEL, MEDIUM LENGTHS AND OR SPECIALS PLEASE CONSULT FACTORY.

DOUBLE EYE, CLOSED MESH



PART NUMBER	DIA. RA.	DESCRIPTION	APPROX. BREAKING STRENGTH	LENGTH	
				E	M
2201-001	.50-.62	R-050-DE	530 LBS.	4	10
2201-002	.63-.74	R-062-DE	790 LBS.	4	10
2201-003	.75-.99	R-075-DE	1020 LBS.	4	13
2201-004	1.00-1.24	R-100-DE	1610 LBS.	5	14
2201-005	1.25-1.49	R-125-DE	1610 LBS.	5	15
2201-006	1.50-1.74	R-150-DE	1610 LBS.	5	17
2201-007	1.75-1.99	R-175-DE	2150 LBS.	6	19
2201-008	2.00-2.49	R-200-DE	3260 LBS.	6	21
2201-009	2.50-2.99	R-250-DE	3260 LBS.	6	23
2201-010	3.00-3.49	R-300-DE	4900 LBS.	8	25
2201-011	3.50-3.99	R-350-DE	4900 LBS.	8	27

DOUBLE EYE, LACE CLOSING

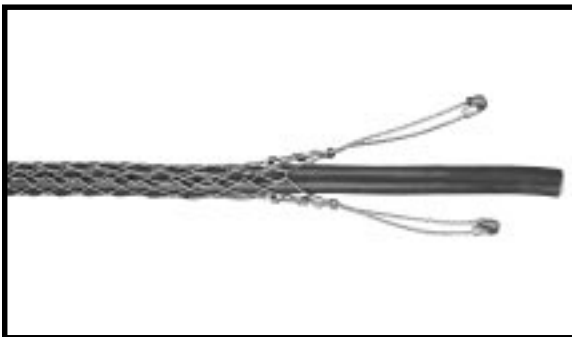

2202-001	.50-.62	RS-050-DE	530 LBS.	4	10
2202-002	.63-.74	RS-062-DE	790 LBS.	4	10
2202-003	.75-.99	RS-075-DE	1020 LBS.	4	13
2202-004	1.00-1.24	RS-100-DE	1610 LBS.	5	14
2202-005	1.25-1.49	RS-125-DE	1610 LBS.	5	15
2202-006	1.50-1.74	RS-150-DE	1610 LBS.	5	17
2202-007	1.75-1.99	RS-175-DE	2150 LBS.	6	19
2202-008	2.00-2.49	RS-200-DE	3260 LBS.	6	21
2202-009	2.50-2.99	RS-250-DE	3260 LBS.	6	23
2202-010	3.00-3.49	RS-300-DE	4900 LBS.	8	25
2202-011	3.50-3.99	RS-350-DE	4900 LBS.	8	27

DOUBLE EYE, ROD CLOSING

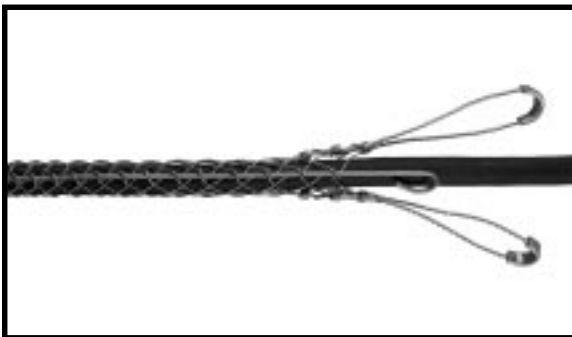

2203-001	.50-.62	RR-050-DE	530 LBS.	4	10
2203-002	.63-.74	RR-062-DE	790 LBS.	4	10
2203-003	.75-.99	RR-075-DE	1020 LBS.	4	13
2203-004	1.00-1.24	RR-100-DE	1610 LBS.	5	14
2203-005	1.25-1.49	RR-125-DE	1610 LBS.	5	15
2203-006	1.50-1.74	RR-150-DE	1610 LBS.	5	17
2203-007	1.75-1.99	RR-175-DE	2150 LBS.	6	19
2203-008	2.00-2.49	RR-200-DE	3260 LBS.	6	21
2203-009	2.50-2.99	RR-250-DE	3260 LBS.	6	23
2203-010	3.00-3.49	RR-300-DE	4900 LBS.	8	25
2203-011	3.50-3.99	RR-350-DE	4900 LBS.	8	27

E = EYE LENGTH M = MESH LENGTH AT NOMINAL DIAMETER (INCHES)

CAUTION: NEVER USE GRIPS TO APPROX. BREAKING STRENGTH REFER TO PG B FOR SAFETY AND WORKING LOAD FACTORS.

AMTEC SUPPORT GRIPS

AMTEC SUPPORT GRIPS ARE MADE OF STRANDED TINNED BRONZE WIRE. STAINLESS STEEL, MEDIUM LENGTHS AND OR SPECIALS PLEASE CONSULT FACTORY.

SINGLE EYE, CLOSED MESH



PART NUMBER	DIA. RA.	DESCRIPTION	APPROX. BREAKING STRENGTH	LENGTH	
				E	M
2201-013	.50-.62	R-050-SE	530 LBS.	7	10
2201-014	.63-.74	R-062-SE	790 LBS.	8	10
2201-015	.75-.99	R-075-SE	1020 LBS.	8	13
2201-016	1.00-1.24	R-100-SE	1610 LBS.	9	14
2201-017	1.25-1.49	R-125-SE	1610 LBS.	10	15
2201-018	1.50-1.74	R-150-SE	1610 LBS.	12	17
2201-019	1.75-1.99	R-175-SE	2150 LBS.	14	19
2201-020	2.00-2.49	R-200-SE	3260 LBS.	16	21
2201-021	2.50-2.99	R-250-SE	3260 LBS.	18	23
2201-022	3.00-3.49	R-300-SE	4900 LBS.	21	25
2201-023	3.50-3.99	R-350-SE	4900 LBS.	24	27

SINGLE EYE, LACE CLOSING



2202-013	.50-.62	RS-050-SE	530 LBS.	7	10
2202-014	.63-.74	RS-062-SE	790 LBS.	8	10
2202-015	.75-.99	RS-075-SE	1020 LBS.	8	13
2202-016	1.00-1.24	RS-100-SE	1610 LBS.	9	14
2202-017	1.25-1.49	RS-125-SE	1610 LBS.	10	15
2202-018	1.50-1.74	RS-150-SE	1610 LBS.	12	17
2202-019	1.75-1.99	RS-175-SE	2150 LBS.	14	19
2202-020	2.00-2.49	RS-200-SE	3260 LBS.	16	21
2202-021	2.50-2.99	RS-250-SE	3260 LBS.	18	23
2202-022	3.00-3.49	RS-300-SE	4900 LBS.	21	25
2202-023	3.50-3.99	RS-350-SE	4900 LBS.	24	27

SINGLE EYE, ROD CLOSING

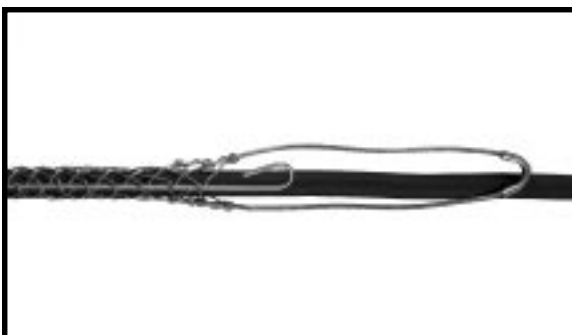

2203-013	.50-.62	RR-050-SE	530 LBS.	7	10
2203-014	.63-.74	RR-062-SE	790 LBS.	8	10
2203-015	.75-.99	RR-075-SE	1020 LBS.	8	13
2203-016	1.00-1.24	RR-100-SE	1610 LBS.	9	14
2203-017	1.25-1.49	RR-125-SE	1610 LBS.	10	15
2203-018	1.50-1.74	RR-150-SE	1610 LBS.	12	17
2203-019	1.75-1.99	RR-175-SE	2150 LBS.	14	19
2203-020	2.00-2.49	RR-200-SE	3260 LBS.	16	21
2203-021	2.50-2.99	RR-250-SE	3260 LBS.	18	23
2203-022	3.00-3.49	RR-300-SE	4900 LBS.	21	25
2203-023	3.50-3.99	RR-350-SE	4900 LBS.	24	27

E = EYE LENGTH M = MESH LENGTH AT NOMINAL DIAMETER (INCHES)

CAUTION: NEVER USE GRIPS TO APPROX. BREAKING STRENGTH. REFER TO PG B FOR SAFETY AND WORKING LOAD FACTORS.

AMTEC SUPPORT GRIPS

AMTEC SUPPORT GRIPS ARE MADE OF STRANDED TINNED BRONZE WIRE. STAINLESS STEEL, MEDIUM LENGTHS AND OR SPECIALS PLEASE CONSULT FACTORY.

OFFSET EYE, CLOSED MESH



PART NUMBER	DIA. RA.	DESCRIPTION	APPROX. BREAKING STRENGTH	LENGTH	
				E	M
2201-025	.50-.62	R-050-OFS	500 LBS.	4	10
2201-026	.63-.74	R-062-OFS	750 LBS.	4	10
2201-027	.75-.99	R-075-OFS	950 LBS.	4	13
2201-028	1.00-1.24	R-100-OFS	1500 LBS.	5	14
2201-029	1.25-1.49	R-125-OFS	1500 LBS.	5	15
2201-030	1.50-1.74	R-150-OFS	1500 LBS.	5	17
2201-031	1.75-1.99	R-175-OFS	2000 LBS.	6	19
2201-032	2.00-2.49	R-200-OFS	3100 LBS.	6	21
2201-033	2.50-2.99	R-250-OFS	3100 LBS.	6	23
2201-034	3.00-3.49	R-300-OFS	3800 LBS.	9	25
2201-035	3.50-3.99	R-350-OFS	3800 LBS.	9	27

OFFSET EYE, LACE CLOSING

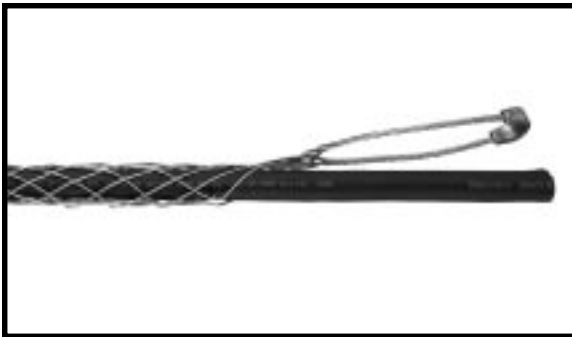

2202-025	.50-.62	RS-050-OFS	500 LBS.	4	10
2202-026	.63-.74	RS-062-OFS	750 LBS.	4	10
2202-027	.75-.99	RS-075-OFS	950 LBS.	4	13
2202-028	1.00-1.24	RS-100-OFS	1500 LBS.	5	14
2202-029	1.25-1.49	RS-125-OFS	1500 LBS.	5	15
2202-030	1.50-1.74	RS-150-OFS	1500 LBS.	5	17
2202-031	1.75-1.99	RS-175-OFS	2000 LBS.	6	19
2202-032	2.00-2.49	RS-200-OFS	3100 LBS.	6	21
2202-033	2.50-2.99	RS-250-OFS	3100 LBS.	6	23
2202-034	3.00-3.49	RS-300-OFS	3800 LBS.	9	25
2202-035	3.50-3.99	RS-350-OFS	3800 LBS.	9	27

OFFSET EYE, ROD CLOSING

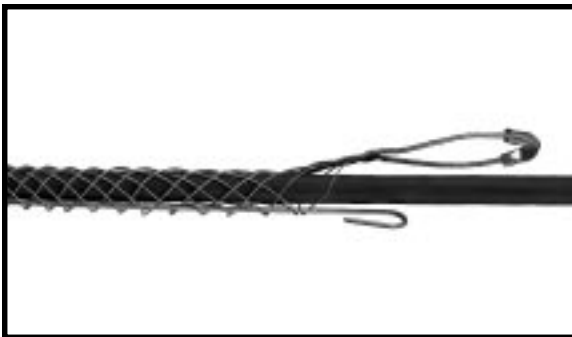

2203-025	.50-.62	RR-050-OFS	500 LBS.	4	10
2203-026	.63-.74	RR-062-OFS	750 LBS.	4	10
2203-027	.75-.99	RR-075-OFS	950 LBS.	4	13
2203-028	1.00-1.24	RR-100-OFS	1500 LBS.	5	14
2203-029	1.25-1.49	RR-125-OFS	1500 LBS.	5	15
2203-030	1.50-1.74	RR-150-OFS	1500 LBS.	5	17
2203-031	1.75-1.99	RR-175-OFS	2000 LBS.	6	19
2203-032	2.00-2.49	RR-200-OFS	3100 LBS.	6	21
2203-033	2.50-2.99	RR-250-OFS	3100 LBS.	6	23
2203-034	3.00-3.49	RR-300-OFS	3800 LBS.	9	25
2203-035	3.50-3.99	RR-350-OFS	3800 LBS.	9	27

E = EYE LENGTH M = MESH LENGTH AT NOMINAL DIAMETER (INCHES)

CAUTION: NEVER USE GRIPS TO APPROX. BREAKING STRENGTH. REFER TO PG B FOR SAFETY AND WORKING LOAD FACTORS.

AMTEC SUPPORT GRIPS

AMTEC SUPPORT GRIPS ARE MADE OF STRANDED TINNED BRONZE WIRE. STAINLESS STEEL, MEDIUM LENGTHS AND OR SPECIALS PLEASE CONSULT FACTORY.

UNIVERSAL BAIL, CLOSED MESH

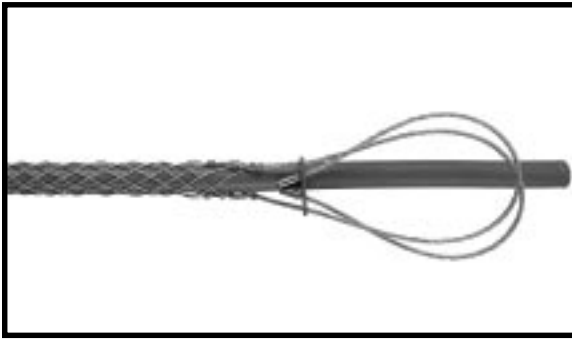

PART NUMBER	DIA. RA.	DESCRIPTION	APPROX. BREAKING STRENGTH	LENGTH	
				E	M
2201-037	.50-.62	R-050-UB-18"	530 LBS.	18	10
2201-038	.63-.74	R-062-UB-18"	790 LBS.	18	10
2201-039	.75-.99	R-075-UB-18"	1020 LBS.	18	13
2201-040	1.00-1.24	R-100-UB-18"	1610 LBS.	18	14
2201-041	1.25-1.49	R-125-UB-18"	1610 LBS.	18	15
2201-042	1.50-1.74	R-150-UB-18"	1610 LBS.	18	17
2201-043	1.75-1.99	R-175-UB-18"	2150 LBS.	18	19
2201-044	2.00-2.49	R-200-UB-18"	3260 LBS.	18	21
2201-045	2.50-2.99	R-250-UB-18"	3260 LBS.	18	23
2201-046	3.00-3.49	R-300-UB-18"	4900 LBS.	18	25
2201-047	3.50-3.99	R-350-UB-18"	4900 LBS.	18	27

UNIVERSAL BAIL, LACE CLOSING



2202-037	.50-.62	RS-050-UB-18"	530 LBS.	18	10
2202-038	.63-.74	RS-062-UB-18"	790 LBS.	18	10
2202-039	.75-.99	RS-075-UB-18"	1020 LBS.	18	13
2202-040	1.00-1.24	RS-100-UB-18"	1610 LBS.	18	14
2202-041	1.25-1.49	RS-125-UB-18"	1610 LBS.	18	15
2202-042	1.50-1.74	RS-150-UB-18"	1610 LBS.	18	17
2202-043	1.75-1.99	RS-175-UB-18"	2150 LBS.	18	19
2202-044	2.00-2.49	RS-200-UB-18"	3260 LBS.	18	21
2202-045	2.50-2.99	RS-250-UB-18"	3260 LBS.	18	23
2202-046	3.00-3.49	RS-300-UB-18"	4900 LBS.	18	25
2202-047	3.50-3.99	RS-350-UB-18"	4900 LBS.	18	27

UNIVERSAL BAIL, ROD CLOSING

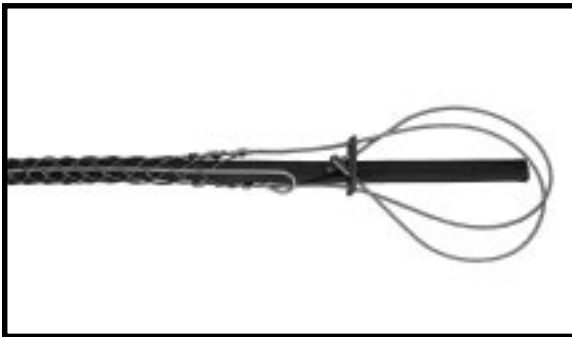

2203-037	.50-.62	RR-050-UB-18"	530 LBS.	18	10
2203-038	.63-.74	RR-062-UB-18"	790 LBS.	18	10
2203-039	.75-.99	RR-075-UB-18"	1020 LBS.	18	13
2203-040	1.00-1.24	RR-100-UB-18"	1610 LBS.	18	14
2203-041	1.25-1.49	RR-125-UB-18"	1610 LBS.	18	15
2203-042	1.50-1.74	RR-150-UB-18"	1610 LBS.	18	17
2203-043	1.75-1.99	RR-175-UB-18"	2150 LBS.	18	19
2203-044	2.00-2.49	RR-200-UB-18"	3260 LBS.	18	21
2203-045	2.50-2.99	RR-250-UB-18"	3260 LBS.	18	23
2203-046	3.00-3.49	RR-300-UB-18"	4900 LBS.	18	25
2203-047	3.50-3.99	RR-350-UB-18"	4900 LBS.	18	27

E = EYE LENGTH M = MESH LENGTH AT NOMINAL DIAMETER (INCHES)

CAUTION: NEVER USE GRIPS TO APPROX. BREAKING STRENGTH. REFER TO PG B FOR SAFETY AND WORKING LOAD FACTORS.

AMTEC SUPPORT GRIPS

AMTEC SUPPORT GRIPS ARE MADE OF STRANDED TINNED BRONZE WIRE. STAINLESS STEEL, MEDIUM LENGTHS AND OR SPECIALS PLEASE CONSULT FACTORY.

HOOK EYE, CLOSED MESH

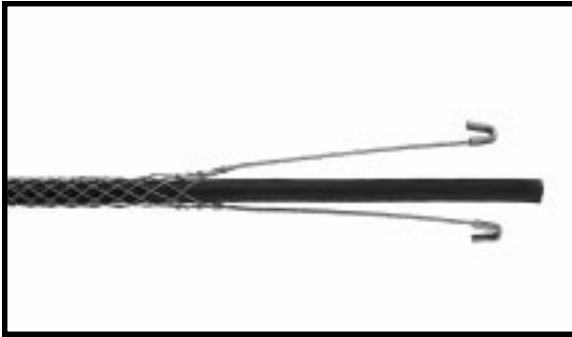

PART NUMBER	DIA. RA.	DESCRIPTION	APPROX. BREAKING STRENGTH	LENGTH	
				E	M
2201-050	.50-.62	R-050-HE	450 LBS.	10	10
2201-051	.63-.74	R-062-HE	750 LBS.	10	10
2201-052	.75-.99	R-075-HE	1000 LBS.	10	13
2201-053	1.00-1.24	R-100-HE	1400 LBS.	10	14
2201-054	1.25-1.49	R-125-HE	1400 LBS.	10	15
2201-055	1.50-1.74	R-150-HE	1400 LBS.	10	17
2201-056	1.75-1.99	R-175-HE	1600 LBS.	10	19
2201-057	2.00-2.49	R-200-HE	2200 LBS.	10	21
2201-058	2.50-2.99	R-250-HE	2200 LBS.	10	23
2201-059	3.00-3.49	R-300-HE	3200 LBS.	10	25
2201-060	3.50-3.99	R-350-HE	3200 LBS.	10	27

HOOK EYE, LACE CLOSING

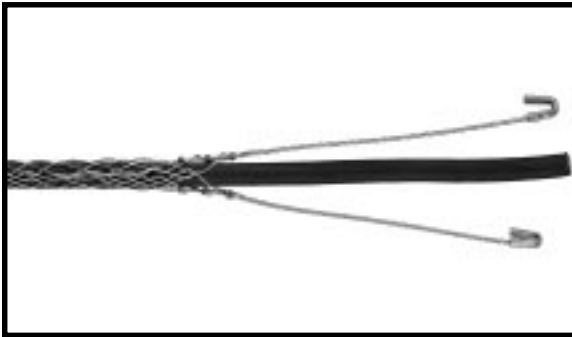

2202-050	.50-.62	RS-050-HE	750 LBS.	10	8 1/2
2202-051	.63-.74	RS-062-HE	750 LBS.	10	8 1/2
2202-052	.75-.99	RS-075-HE	1000 LBS.	10	10 1/2
2202-053	1.00-1.24	RS-100-HE	1400 LBS.	10	12 1/2
2202-054	1.25-1.49	RS-125-HE	1400 LBS.	10	14 1/2
2202-055	1.50-1.74	RS-150-HE	1400 LBS.	10	15 1/2
2202-056	1.75-1.99	RS-175-HE	1600 LBS.	10	16 1/2
2202-057	2.00-2.49	RS-200-HE	2200 LBS.	10	19 1/2
2202-058	2.50-2.99	RS-250-HE	2200 LBS.	10	21 1/2
2202-059	3.00-3.49	RS-300-HE	3200 LBS.	10	23 1/2
2202-060	3.50-3.99	RS-350-HE	3200 LBS.	10	25 1/2

HOOK EYE, ROD CLOSING

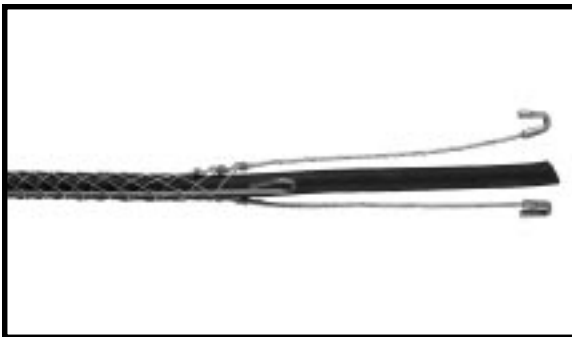

2203-050	.50-.62	RR-050-HE	750 LBS.	10	8 1/2
2203-051	.63-.74	RR-062-HE	750 LBS.	10	8 1/2
2203-052	.75-.99	RR-075-HE	1000 LBS.	10	10 1/2
2203-053	1.00-1.24	RR-100-HE	1400 LBS.	10	12 1/2
2203-054	1.25-1.49	RR-125-HE	1400 LBS.	10	14 1/2
2203-055	1.50-1.74	RR-150-HE	1400 LBS.	10	15 1/2
2203-056	1.75-1.99	RR-175-HE	1600 LBS.	10	16 1/2
2203-057	2.00-2.49	RR-200-HE	2200 LBS.	10	19 1/2
2203-058	2.50-2.99	RR-250-HE	2200 LBS.	10	21 1/2
2203-059	3.00-3.49	RR-300-HE	3200 LBS.	10	23 1/2
2203-060	3.50-3.99	RR-350-HE	3200 LBS.	10	25 1/2

E = EYE LENGTH M = MESH LENGTH AT NOMINAL DIAMETER (INCHES)

CAUTION: NEVER USE GRIPS TO APPROX. BREAKING STRENGTH. REFER TO PG B FOR SAFETY AND WORKING LOAD FACTORS.

AMTEC HEAVY DUTY SUPPORT GRIPS

AMTEC HEAVY DUTY SUPPORT GRIPS ARE DESIGNED TO WITHSTAND GREATER LOADS AND INCREASED STRESS. SUPPORT GRIPS ARE MADE OF STRANDED TINNED BRONZE WIRE. STAINLESS STEEL, MEDIUM LENGTHS AND OR SPECIALS PLEASE CONSULT FACTORY.

SINGLE EYE, CLOSED MESH , DOUBLE WEAVE

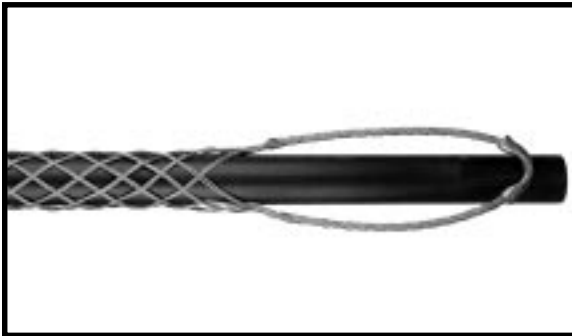

PART NUMBER	DIA. RA.	DESCRIPTION	APPROX. BREAKING STRENGTH	LENGTH	
				E	M
2206-001	.75-.99	P-075-SE	2820 LBS.	10	25
2206-002	1.00-1.24	P-100-SE	4280 LBS.	10	28
2206-003	1.25-1.49	P-125-SE	4280 LBS.	10	30
2206-004	1.50-1.99	P-150-SE	4280 LBS.	10	34

DOUBLE EYE, CLOSED MESH, DOUBLE WEAVE

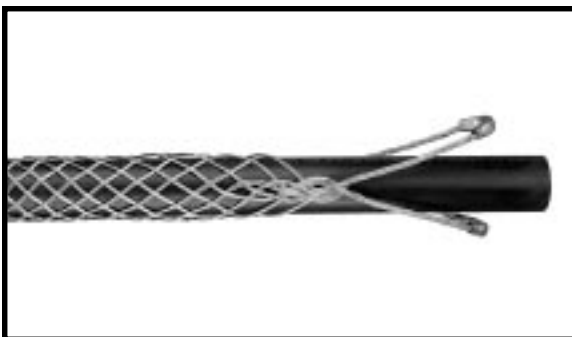

2206-006	.75-.99	P-075-DE	2820 LBS.	10	25
2206-007	1.00-1.24	P-100-DE	4280 LBS.	10	28
2206-008	1.25-1.49	P-125-DE	4280 LBS.	10	30
2206-009	1.50-1.99	P-150-DE	4280 LBS.	10	34
2206-010	2.00-2.49	P-200-DE	8050 LBS.	10	36
2206-011	2.50-2.99	P-250-DE	8050 LBS.	10	38
2206-012	3.00-3.49	P-300-DE	10060 LBS.	10	40
2206-013	3.50-3.99	P-350-DE	12070 LBS.	10	44
2206-014	4.00-4.49	P-400-DE	12070 LBS.	10	46

E = EYE LENGTH M = MESH LENGTH AT NOMINAL DIAMETER (INCHES)

CAUTION: NEVER USE GRIPS TO APPROX. BREAKING STRENGTH. REFER TO PG B FOR SAFETY AND WORKING LOAD FACTORS.

AMTEC SERVICE DROPS

AMTEC SERVICE DROP GRIPS ARE USED IN A WIDE VARIETY OF LIGHT DUTY ELECTRICAL APPLICATIONS SUCH AS SERVICE ENTRANCE, CABLE TV, TELEPHONE, FIBER OPTICS, ETC., IN SLOPING, VERTICAL OR HORIZONTAL POSITIONS. THE MESH IS MADE FROM HIGH GRADE NON-MAGNETIC TIN COATED BRONZE WIRE. AMTEC SERVICE DROP GRIPS ARE EASILY INSTALLED WIDE RANGE SINGLE AND MULTI-WEAVE MESH. A STAINLESS STEEL TYPE 302/304 NON-CORROSIVE MESH FOR SEVERE APPLICATIONS IS AVAILABLE UPON REQUEST.

STANDARD, SINGLE EYE

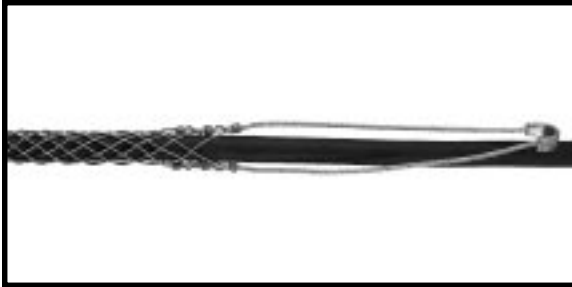

PART NUMBER	DIA. RA.	DESCRIPTION	APPROX. BREAKING STRENGTH	LENGTH	
				E	M
2216-001	.23-.31	SD-23	290 LBS.	4	3 3/4
2216-002	.32-.43	SD-32	290 LBS.	4	4 1/4
2216-003	.43-.56	SD-43	380 LBS.	6	5
2216-004	.56-.73	SD-56	600 LBS.	7	6
2216-005	.73-.85	SD-73	790 LBS.	7	6 3/4
2216-006	.85-1.00	SD-85	1020 LBS.	8	8
2216-007	1.00-1.25	SD-100	1020 LBS.	9	9 1/2

STANDARD, UNIVERSAL BAIL

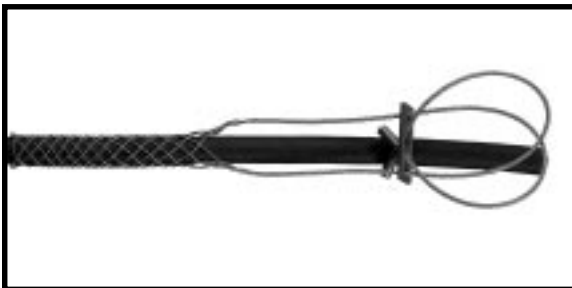

2216-008	.23-.31	SD-23-UB	290 LBS.	8	3 3/4
2216-009	.32-.43	SD-32-UB	290 LBS.	10	4 1/4
2216-010	.43-.56	SD-43-UB	380 LBS.	12	5
2216-011	.56-.73	SD-56-UB	600 LBS.	13	6
2216-012	.73-.85	SD-73-UB	790 LBS.	14	6 3/4
2216-013	.85-1.00	SD-85-UB	1020 LBS.	14	8
2216-014	1.00-1.25	SD-100-UB	1020 LBS.	15	9 1/2

HEAVY DUTY, SINGLE EYE



2217-001	.23-.31	SDH-23	500 LBS.	5	5
2217-002	.32-.43	SDH-32	500 LBS.	6	6 1/2
2217-003	.43-.56	SDH-43	870 LBS.	6	8
2217-004	.56-.73	SDH-56	1050 LBS.	7	9
2217-005	.73-.85	SDH-73	1390 LBS.	8	10 1/2
2217-006	.85-1.00	SDH-85	1790 LBS.	8	12
2217-007	1.00-1.25	SDH-100	1790 LBS.	9	14

HEAVY DUTY, UNIVERSAL BAIL



2217-008	.23-.31	SDH-23-UB	500 LBS.	9	5
2217-009	.32-.43	SDH-32-UB	500 LBS.	10	6 1/2
2217-010	.43-.56	SDH-43-UB	870 LBS.	12	8
2217-011	.56-.73	SDH-56-UB	1050 LBS.	13	9 1/2
2217-012	.73-.85	SDH-73-UB	1390 LBS.	14	10 1/2
2217-013	.85-1.00	SDH-85-UB	1790 LBS.	14	12
2217-014	1.00-1.25	SDH-100-UB	1790 LBS.	15	14

E = EYE LENGTH M = MESH LENGTH AT NOMINAL DIAMETER (INCHES)

CAUTION: NEVER USE GRIPS TO APPROX. BREAKING STRENGTH. REFER TO PG B FOR SAFETY AND WORKING LOAD FACTORS.

AMTEC CONDUIT RISER GRIPS

AMTEC CONDUIT RISER SUPPORT GRIPS ARE USED TO SUPPORT CABLE RUNS IN VERTICAL OR SLOPING STANDARD RIGID CONDUIT. THEY ARE DESIGNED TO PREVENT CABLE CREEP IN CONDUIT AND HELP PREVENT CABLE PULLOUTS. AMTEC CONDUIT RISER SUPPORT GRIPS INSTALL QUICKLY AND EASILY WITH NO DAMAGE TO ELECTRICAL CABLE. THE MESH IS ATTACHED TO A SUPPORT RING WHICH SITS ON THE CONDUIT REQUIRING NO EXTRA HARDWARE TO ATTACH. FITTINGS, BUSHINGS OR COUPLINGS MAY BE THREADED ON THE CONDUIT WITH THE GRIP IN PLACE. AMTEC CONDUIT RISER GRIPS ARE MADE OF STRANDED TINNED BRONZE WIRE. STAINLESS STEEL, DOUBLE WEAVE AND OR SPECIALS, PLEASE CONSULT FACTORY.

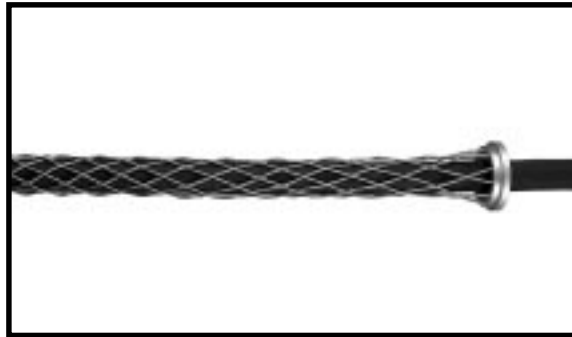

SINGLE WEAVE, CLOSED MESH

	CABLE SIZE INCHES	.50-.62	.63-.74	.75-.99	1.00-1.24	1.25-1.49	1.50-1.74	1.75-1.99	2.00-2.49	2.50-2.99	3.00-3.49	3.50-3.99
	MODEL	R-050	R-062	R-075	R-100	R-125	R-150	R-175	R-200	R-250	R-300	R-350
	LENGTH	8"	9"	10"	11"	12"	13"	14"	17"	18"	20"	21"
CONDUIT SIZE	APX. BRK. STR. LBS.	530 290	790 435	1030 560	1610 890	1610 890	1610 890	2150 1180	3260 1795	3260 1795	4080 2245	4080 2245
3/4"	CAT. NO.	2211-001										
1"	CAT. NO.	2211-002	2211-003									
1- 1/4"	CAT. NO.	2211-004	2211-005	2211-006								
1-1/2"	CAT. NO.	2211-007	2211-008	2211-009	2211-010							
2"	CAT. NO.	2211-011	2211-012	2211-013	2211-014	2211-015						
2-1/2"	CAT. NO.	2211-016	2211-017	2211-018	2211-019	2211-020	2211-022	2211-023				
3"	CAT. NO.	2211-024	2211-025	2211-026	2211-027	2211-028	2211-029	2211-030	2211-031			
3-1/2"	CAT. NO.		2211-032	2211-033	2211-034	2211-035	2211-036	2211-037	2211-038	2211-039		
4"	CAT. NO.		2211-040	2211-041	2211-042	2211-043	2211-044	2211-045	2211-046	2211-047	2211-048	
4 1/2"	CAT. NO.			2211-049	2211-050	2211-051	2211-052	2211-053	2211-054	2211-055	2211-056	2211-057
5"	CAT. NO.			2211-058	2211-059	2211-060	2211-061	2211-062	2211-063	2211-064	2211-065	2211-066
6"	CAT. NO.			2211-067	2211-068	2211-069	2211-070	2211-071	2211-072	2211-073	2211-074	2211-075

AMTEC CONDUIT RISER GRIPS

AMTEC CONDUIT RISER GRIPS ARE MADE OF STRANDED TINNED BRONZE WIRE. STAINLESS STEEL, MEDIUM LENGTHS AND OR SPECIALS, PLEASE CONSULT FACTORY.

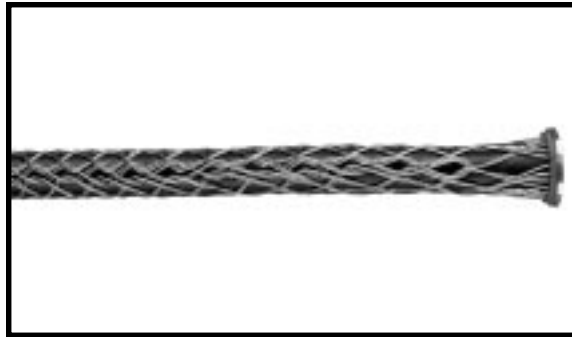

DOUBLE WEAVE, SPLIT MESH, LACE CLOSING

	CABLE SIZE INCHES	.75-.99	1.00-1.24	1.25-1.49	1.50-1.74	1.75-1.99	2.00-2.49	2.50-2.99	3.00-3.49	3.50-3.99
	MODEL	RS-075	RS-100	RS-125	RS-150	RS-175	RS-200	RS-250	RS-300	RS-350
	LENGTH	10"	11"	12"	13"	14"	17"	18"	20"	21"
CONDUIT SIZE	APX.BRK. STR.LBS.	1580 870	2040 1125	2040 1125	2040 1125	2730 1500	4300 2365	4300 2365	5380 2955	5380 2955
1-1/4"	CAT NO	2212-006								
1-1/2"	CAT NO	2212-009	2212-010							
2"	CAT NO	2212-013	2212-014	2212-015						
2-1/2"	CAT NO	2212-018	2212-019	2212-020	2212-022	2212-023				
3"	CAT NO	2212-026	2212-027	2212-028	2212-029	2212-030	2212-031			
3-1/2"	CAT NO	2212-033	2212-034	2212-035	2212-036	2212-037	2212-038	2212-039		
4"	CAT NO	2212-041	2212-042	2212-043	2212-044	2212-045	2212-046	2212-047	2212-048	
4-1/2"	CAT NO	2212-049	2212-050	2212-051	2212-052	2212-053	2212-054	2212-055	2212-056	2212-057
5"	CAT NO	2212-058	2212-059	2212-060	2212-061	2212-062	2212-063	2212-064	2212-065	2212-066
6"	CAT NO	2212-067	2212-068	2212-069	2212-070	2212-071	2212-072	2212-073	2212-074	2212-075

AMTEC CONDUIT RISER GRIPS

AMTEC CONDUIT RISER GRIPS ARE MADE OF STRANDED TINNED BRONZE WIRE. STAINLESS STEEL, MEDIUM LENGTHS AND OR SPECIALS, PLEASE CONSULT FACTORY.

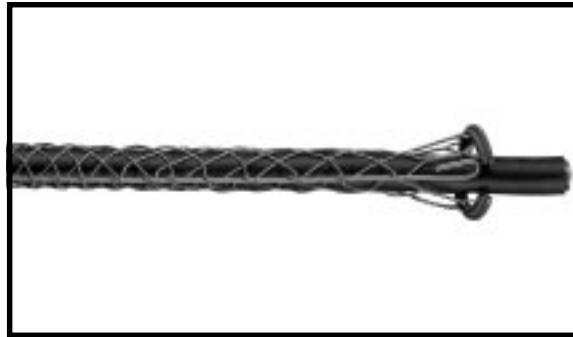

SINGLE WEAVE, SPLIT MESH, ROD CLOSING

	CABLE SIZE INCHES	.75-.99	1.00-1.24	1.25-1.49	1.50-1.74	1.75-1.99	2.00-2.49	2.50-2.99	3.00-3.49	3.50-3.99
	MODEL	RR-075	RR-100	RR-125	RR-150	RR-175	RR-200	RR-250	RR-300	RR-350
	LENGTH	11"	12"	13"	14"	15"	16"	17"	19"	20"
CONDUIT SIZE	APX.BRK. STR.LBS.	1020 560	1610 890	1610 890	1610 890	2150 1180	3260 1795	3260 1795	4080 2245	4080 2245
1-1/4"	CAT NO	2213-006								
1-1/2"	CAT NO	2213-009	2213-010							
2"	CAT NO	2213-013	2213-014	2213-015						
2-1/2"	CAT NO	2213-018	2213-019	2213-020	2213-022	2213-023				
3"	CAT NO	2213-026	2213-027	2213-028	2213-029	2213-030	2213-031			
3-1/2"	CAT NO	2213-033	2213-034	2213-035	2213-036	2213-037	2213-038	2213-039		
4"	CAT NO	2213-041	2213-042	2213-043	2213-044	2213-045	2213-046	2213-047	2213-048	
4-1/2"	CAT NO	2213-049	2213-050	2213-051	2213-052	2213-053	2213-054	2213-055	2213-056	2213-057
5"	CAT NO	2213-058	2213-059	2213-060	2213-061	2213-062	2213-063	2213-064	2213-065	2213-066
6"	CAT NO	2213-067	2213-068	2213-069	2213-070	2213-071	2213-072	2213-073	2213-074	2213-075

AMTEC CONDUIT RISER

CONDUIT RINGS

SELECT CONDUIT RING DIMENSION FROM CHART TO THE RIGHT.
CONDUIT RINGS ARE CAST BRONZE, ZINC PLATED TO RESIST CORROSION.

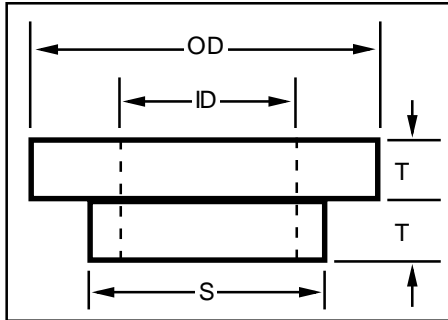

CONDUIT RING DIMENSIONS

CONDUIT SIZE	RING NO.				
		O.D.	I.D.	S	T
3/4"	C-3/4"	.94	.62	-	.19
1"	C-1	1.31	.93	-	.19
1-1/4"	C-1-1/4"	1.50	1.03	1.31	.16
1-1/2"	C-1-1/2"	1.76	1.23	1.52	.16
2"	C-2	2.23	1.55	1.97	.16
2-1/2"	C-2-1/2"	2.67	2.05	2.40	.16
3"	C-3	3.20	2.55	2.97	.22
3-1/2"	C-3-1/2"	3.80	3.05	3.47	.22
4"	C-4	4.30	3.55	3.94	.22
4-1/2"	C-4-1/2"	4.80	4.03	4.45	.22
5"	C-5	5.30	4.46	4.96	.22
6"	C-6	6.30	5.36	5.96	.25

FOR AMTEC CONDUIT RISER GRIPS ONLY
USE TO DETERMINE GRIP SIZE WHEN MULTIPLE CABLES ARE HELD
IN A SINGLE CONDUIT RISER GRIP

FOR
CABLES
OF
EQUAL
DIAMETERS

UNDER "NUMBER OF CABLES IN ONE GRIP," FIND DIAMETER OF YOUR
CABLE IN VERTICAL COLUMN. READ GRIP SIZE AND GRIP DIAMETER
RANGE TO THE RIGHT.
IF YOUR DIAMETER IS THE MAXIMUM OF THE RANGE SHOWN, GO TO
THE NEXT LARGER SIZE FOR SPLIT GRIPS, STAY WITH THE SAME SIZE
FOR CLOSED GRIPS.
EXAMPLE: 3 CABLES, EACH WITH .85 DIAMETER, FOR A CLOSED GRIP
SELECT THE 1.50-1.74 RANGE, FOR A SPLIT GRIP USE 1.75 - 1.99.

NUMBER OF EQUAL DIAMETER CABLES IN ONE GRIP							
2	3	4	5	6 and 7	8	9	GRIP DIAM. RANGE
.29-.36 .37-.43 .44-.58	.24-.30 .31-.36 .37-.48	.21-.25 .26-.30 .31-.41	.18-.22 .23-.27 .28-.36	.16-.20 .21-.24 .25-.32	.15-.18 .19-.22 .23-.29	.14-.17 .18-.20 .21-.27	.50-.62 .63-.74 .75-.99
.59-.72 .73-.87 .88-1.01	.49-.60 .61-.72 .73-.85	.42-.51 .52-.61 .62-.71	.37-.45 .46-.54 .55-.63	.33-.40 .41-.48 .49-.56	.30-.36 .37-.43 .44-.51	.28-.34 .35-.40 .41-.47	1.00-1.24 1.25-1.49 1.50-1.74
1.02-1.16 1.17-1.44 1.45-1.73	.86-.96 .97-1.20 1.21-1.45	.72-.81 .82-1.02 1.03-1.22	.64-.72 .73-.90 .91-1.08	.57-.64 .65-.80 .81-.96	.52-.58 .59-.72 .73-.87	.48-.54 .55-.67 .68-.81	1.75-1.99 2.00-2.49 2.50-2.99
1.74-2.02 2.03-2.31	1.46-1.69 1.70-1.93	1.23-1.43 1.44-1.63	1.09-1.26 1.27-1.44	.97-1.11 1.12-1.27	.83-1.01 1.02-1.15	.82-.94 .95-1.08	3.00-3.49 3.50-3.99

AMTEC UTILITY PULLING GRIPS

AMTEC UTILITY PULLING GRIPS ARE MADE OF HIGH STRENGTH GALVANIZED STEEL STRAND. PULLING GRIPS ARE DOUBLE WEAVE FOR ADDED STRENGTH WITH GREATER MESH CONTACT ON THE CABLE TO HANDLE LONGER OR HEAVIER PULLING JOBS.

STANDARD, MACHINED EYE



PART NUMBER	DIA. RA.	DESCRIPTION	APPROX. BREAKING STRENGTH	LENGTH	
				E	M
3301-001	.50-.61	UP-50-ME	5600 LBS.	5	16
3301-002	.62-.74	UP-62-ME	6800 LBS.	5	16
3301-003	.75-.99	UP-75-ME	9600 LBS.	6	32
3301-004	1.00-1.49	UP-100-ME	16400 LBS.	7	33
3301-005	1.50-1.99	UP-150-ME	16400 LBS.	7	34
3301-006	2.00-2.49	UP-200-ME	27200 LBS.	9	36
3301-007	2.50-2.99	UP-250-ME	33000 LBS.	10	38
3301-008	3.00-3.49	UP-300-ME	41000 LBS.	10	39
3301-009	3.50-3.99	UP-350-ME	48000 LBS.	10	41
3301-010	4.00-4.49	UP-400-ME	48000 LBS.	10	42
3301-011	4.50-4.99	UP-450-ME	48000 LBS.	10	58
3301-012	5.00-5.99	UP-500-ME	48000 LBS.	10	60
3301-013	6.00-6.99	UP-600-ME	48000 LBS.	10	66

STANDARD, FLEXIBLE EYE

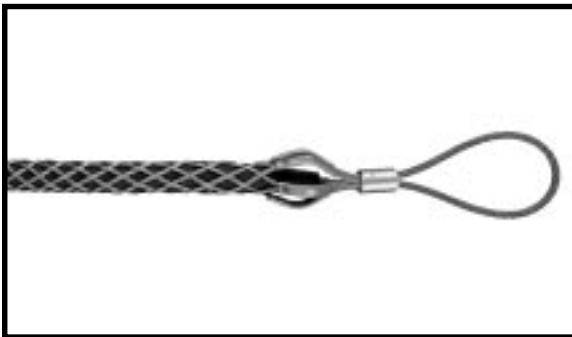

3304-001	.50-.61	UP-50-FE	4500 LBS.	5	16
3304-002	.62-.74	UP-62-FE	5600 LBS.	5	16
3304-003	.75-.99	UP-75-FE	6800 LBS.	6	32
3304-004	1.00-1.49	UP-100-FE	9600 LBS.	7	33
3304-005	1.50-1.99	UP-150-FE	16400 LBS.	7	34
3304-006	2.00-2.49	UP-200-FE	18500 LBS.	9	36
3304-007	2.50-2.99	UP-250-FE	24500 LBS.	10	38
3304-008	3.00-3.49	UP-300-FE	24500 LBS.	10	39
3304-009	3.50-3.99	UP-350-FE	31000 LBS.	10	41

FOR SHORTER OR LONGER MESH PLEASE CONSULT FACTORY.

CAUTION: NEVER USE GRIPS TO APPROX. BREAKING STRENGTH. REFER TO PG B FOR SAFETY AND WORKING LOAD FACTORS.

AMTEC LIGHT DUTY PULLING GRIPS

AMTEC LIGHT DUTY PULLING GRIPS ARE MADE OF HIGH GRADE GALVANIZED STEEL STRAND. THEY ARE SINGLE WEAVE WITH A FLEXIBLE EYE FOR EASY ATTACHMENT TO A PULLING LINE. AMTEC LIGHT DUTY PULLING GRIPS ARE USED IN GENERAL UNDERGROUND ELECTRICAL CONSTRUCTION WHERE PULLING TENSIONS ARE LOW.

SHORT



PART NUMBER	DIA. RA.	DESCRIPTION	APPROX. BREAKING STRENGTH	LENGTH	
				E	M
3303-001	.50-.61	LD-050-S	2800 LBS.	5	11
3303-002	.62-.74	LD-062-S	2800 LBS.	5	11
3303-003	.75-.99	LD-075-S	4000 LBS.	6	12
3303-004	1.00-1.24	LD-100-S	5300 LBS.	7	13
3303-005	1.25-1.49	LD-125-S	5300 LBS.	7	14
3303-006	1.50-1.74	LD-150-S	6800 LBS.	8	15
3303-007	1.75-1.99	LD-175-S	8500 LBS.	8	17
3303-008	2.00-2.49	LD-200-S	8500 LBS.	9	18
3303-009	2.50-2.99	LD-250-S	10600 LBS.	9	18
3303-010	3.00-3.49	LD-300-S	14700 LBS.	10	20

STANDARD



3303-011	.50-.61	LD-050	2800 LBS.	5	16
3303-012	.62-.74	LD-062	2800 LBS.	5	16
3303-013	.75-.99	LD-075	4000 LBS.	6	20
3303-014	1.00-1.24	LD-100	6800 LBS.	7	20
3303-015	1.25-1.49	LD-125	6800 LBS.	7	21
3303-016	1.50-1.99	LD-150	6800 LBS.	8	23
3303-017	2.00-2.49	LD-200	8500 LBS.	9	25
3303-018	2.50-2.99	LD-250	10600 LBS.	9	27
3303-019	3.00-3.50	LD-300	14700 LBS.	10	30
3303-020	3.50-3.99	LD-350	14700 LBS.	10	32

JUNIOR PULLING

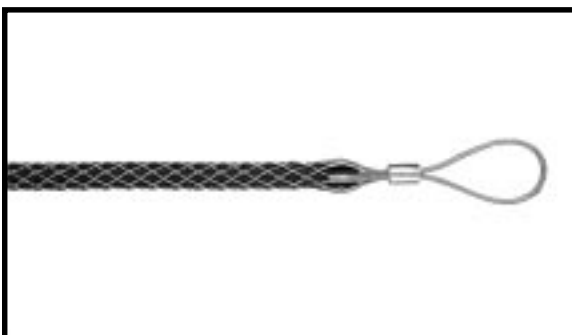

3305-002	.25-.36	JP-25	450 LBS.	3	1/4	4	1/4
3305-003	.37-.49	JP-37	900 LBS.	3	1/4	7	
3305-004	.50-.61	JP-50	1300 LBS.	4	1/4	8	1/2
3305-005	.62-.74	JP-62	1950 LBS.	5		10	
3305-006	.75-.99	JP-75	2800 LBS.	5	3/4	10	
3305-007	1.00-1.25	JP-100	3900 LBS.	6	1/2	11	1/2
3305-008	.25-1.25	JKIT					
INCLUDES:		JP-25, JP-37 JP-50, JP-62 JP-75, JP-100					

E = EYE LENGTH M = MESH LENGTH AT NOMINAL DIAMETER (INCHES)

CAUTION: NEVER USE GRIPS TO APPROX. BREAKING STRENGTH. REFER TO PG B FOR SAFETY AND WORKING LOAD FACTORS.

AMTEC SLACK PULLING GRIPS

AMTEC SLACK PULLING GRIPS ARE MADE OF GALVANIZED STEEL AND COME IN THREE STYLES WITH A SINGLE OFFSET EYE FOR EASY ATTACHMENT TO A PULLING LINE. CLOSED, WHEN THE CABLE END IS ACCESSIBLE, SPLIT LACE AND ROD CLOSING WHEN CABLE END IS NOT ACCESSIBLE. GRIPS ARE USED IN PULLING SLACK FOR FINAL PLACEMENT OF UNDERGROUND CABLE AFTER IT HAS BEEN PULLED AND FOR REMOVING CABLE. SHORT MESH TO BE USED IN RESTRICTED SPACE FOR SHORT PULLS AND LONGER MESH FOR HIGHER PULLING LOADS WHERE SPACE IS NOT RESTRICTED.

STANDARD

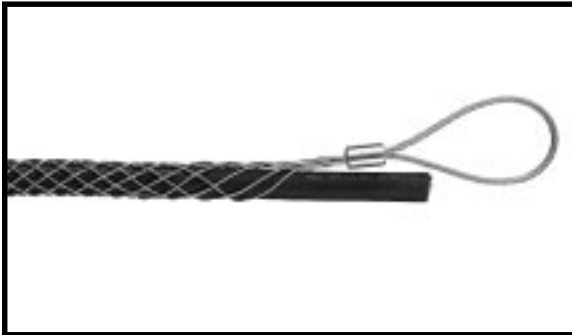

PART NUMBER	DIA. RA.	DESCRIPTION	APPROX. BREAKING STRENGTH	LENGTH	
				E	M
3308-001	.50-.61	SPG-50-SW	1000 LBS.	6	11
3308-002	.62-.74	SPG-62-SW	1200 LBS.	6	12
3308-003	.75-.99	SPG-75-SW	1750 LBS.	7	12
3308-004	1.00-1.24	SPG-100-SW	2500 LBS.	8	15
3308-005	1.25-1.49	SPG-125-SW	2500 LBS.	8	16
3308-006	1.50-1.74	SPG-150-SW	3000 LBS.	9	17
3308-007	1.75-1.99	SPG-175-SW	3500 LBS.	10	18
3308-008	2.00-2.49	SPG-200-SW	5000 LBS.	10	19
3308-009	2.50-2.99	SPG-250-SW	5000 LBS.	10	20
3308-010	3.00-3.49	SPG-300-SW	8000 LBS.	12	21
3308-011	3.50-3.99	SPG-350-SW	8000 LBS.	12	22

STANDARD DOUBLE WEAVE

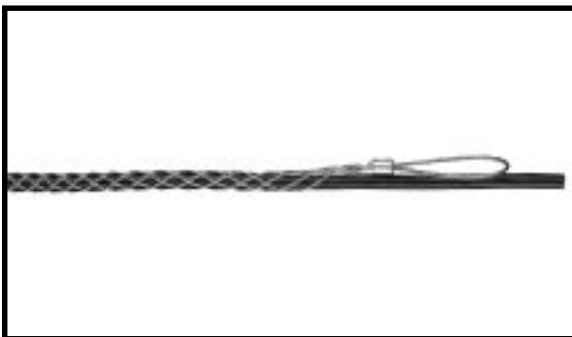

3308-015	.75-.99	SPG-75-DW	2600 LBS.	7	12
3308-016	1.00-1.24	SPG-100-DW	4000 LBS.	8	15
3308-017	1.25-1.49	SPG-125-DW	5400 LBS.	8	16
3308-018	1.50-1.74	SPG-150-DW	6600 LBS.	9	17
3308-019	1.75-1.99	SPG-175-DW	10000 LBS.	10	18
3308-020	2.00-2.49	SPG-200-DW	11000 LBS.	10	19
3308-021	2.50-2.99	SPG-250-DW	11000 LBS.	10	20
3308-022	3.00-3.49	SPG-300-DW	14500 LBS.	12	21
3308-023	3.50-3.99	SPG-350-DW	14500 LBS.	12	22

LONG DOUBLE WEAVE

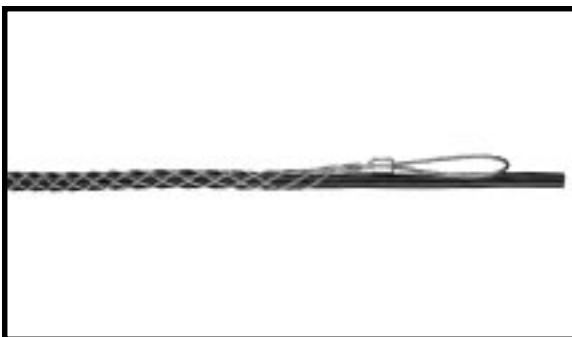

3308-026	.75-.99	SPG-75-DW-L	2600 LBS.	7	20
3308-027	1.00-1.24	SPG-100-DW-L	4000 LBS.	8	20
3308-028	1.25-1.49	SPG-125-DW-L	5400 LBS.	8	23
3308-029	1.50-1.99	SPG-150-DW-L	10000 LBS.	9	25
3308-030	2.00-2.49	SPG-200-DW-L	11000 LBS.	10	26
3308-031	2.50-2.99	SPG-250-DW-L	11000 LBS.	10	29
3308-032	3.00-3.49	SPG-300-DW-L	14500 LBS.	12	32
3308-033	3.50-3.99	SPG-350-DW-L	14500 LBS.	12	35

E = EYE LENGTH M = MESH LENGTH AT NOMINAL DIAMETER (INCHES)

CAUTION: NEVER USE GRIPS TO APPROX. BREAKING STRENGTH. REFER TO PG B FOR SAFETY AND WORKING LOAD FACTORS.

AMTEC SLACK PULLING GRIPS

AMTEC SLACK PULLING GRIPS ARE MADE OF GALVANIZED STEEL AND COME IN THREE STYLES WITH A SINGLE OFFSET EYE FOR EASY ATTACHMENT TO A PULLING LINE. CLOSED, WHEN THE CABLE END IS ACCESSIBLE, SPLIT LACE AND ROD CLOSING WHEN CABLE END IS NOT ACCESSIBLE. GRIPS ARE USED IN PULLING SLACK FOR FINAL PLACEMENT OF UNDERGROUND CABLE AFTER IT HAS BEEN PULLED AND FOR REMOVING CABLE. SHORT MESH TO BE USED IN RESTRICTED SPACE FOR SHORT PULLS AND LONGER MESH FOR HIGHER PULLING LOADS WHERE SPACE IS NOT RESTRICTED.

STANDARD LACE CLOSING

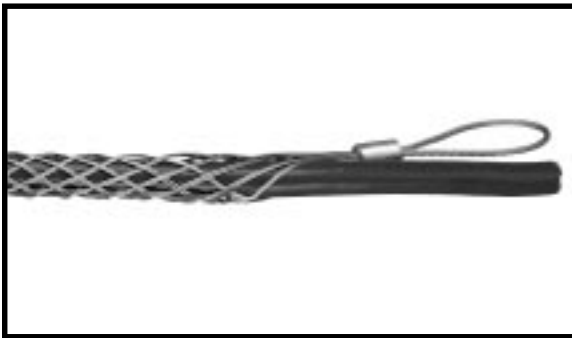

PART NUMBER	DIA. RA.	DESCRIPTION	APPROX. BREAKING STRENGTH	LENGTH	
				E	M
3309-001	.75-.99	SPGS-75-DW	2500 LBS.	7	12
3309-002	1.00-1.24	SPGS-100-DW	3500 LBS.	8	15
3309-003	1.25-1.49	SPGS-125-DW	4000 LBS.	8	16
3309-004	1.50-1.74	SPGS-150-DW	4000 LBS.	9	17
3309-005	1.75-1.99	SPGS-175-DW	4000 LBS.	10	18
3309-006	2.00-2.49	SPGS-200-DW	4000 LBS.	10	19
3309-007	2.50-2.99	SPGS-250-DW	4000 LBS.	10	20
3309-008	3.00-3.49	SPGS-300-DW	4000 LBS.	12	21
3309-009	3.50-3.99	SPGS-350-DW	4000 LBS.	12	22

STANDARD ROD CLOSING



3310-001	.50-.61	SPGR-50-SW	1500 LBS.	7	6
3310-002	.62-.74	SPGR-62-SW	1800 LBS.	7	8
3310-003	.75-.99	SPGR-75-SW	2200 LBS.	7	10
3310-004	1.00-1.24	SPGR-100-SW	3400 LBS.	8	12
3310-005	1.25-1.49	SPGR-125-SW	4500 LBS.	8	14
3310-006	1.50-1.74	SPGR-150-SW	5800 LBS.	9	15
3310-007	1.75-1.99	SPGR-175-SW	7600 LBS.	10	16
3310-008	2.00-2.49	SPGR-200-SW	9000 LBS.	10	19
3310-009	2.50-2.99	SPGR-250-SW	11000 LBS.	10	20
3310-010	3.00-3.49	SPGR-300-SW	12000 LBS.	12	21
3310-011	3.50-3.99	SPGR-350-SW	12000 LBS.	12	24

E = EYE LENGTH M = MESH LENGTH AT NOMINAL DIAMETER (INCHES)

CAUTION: NEVER USE GRIPS TO APPROX. BREAKING STRENGTH. REFER TO PG B FOR SAFETY AND WORKING LOAD FACTORS.

AMTEC TUBE GRIPS

AMTEC TUBE GRIPS ARE MADE OF GALVANIZED STEEL IN EITHER SINGLE OR DOUBLE WEAVE. THEY ARE USED AS A TEMPORARY SPLICE FOR ROPES AND WIRE ROPES AS WELL AS CABLE REINFORCEMENTS.

SINGLE WEAVE

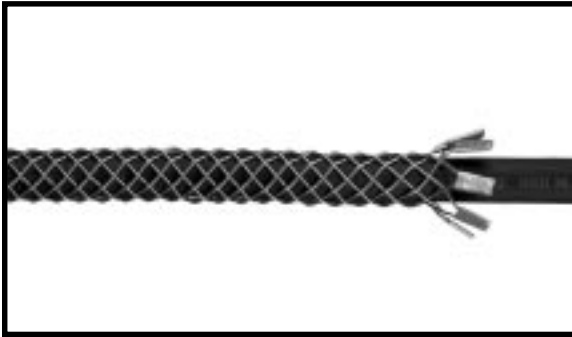

PART NUMBER	DIA. RA.	DESCRIPTION	APPROX. BREAKING STRENGTH
1303-001	.19-.24	TG-19-7"	400 LBS.
1303-002	.25-.37	TG-25-8"	400 LBS.
1303-003	.37-.50	TG-37-18"	1700 LBS.
1303-004	.50-.62	TG-50-18"	2500 LBS.
1303-005	.50-.62	TG-50-24"	2500 LBS.
1303-006	.62-.74	TG-62-18"	3100 LBS.
1303-007	.62-.74	TG-62-24"	3100 LBS.
1303-008	.62-.74	TG-62-36"	3100 LBS.
1303-009	.75-.99	TG-75-24"	5000 LBS.
1303-010	.75-.99	TG-75-36"	5000 LBS.
1303-011	.75-.99	TG-75-48"	5000 LBS.
1303-012	.75-.99	TG-75-60"	5000 LBS.
1303-013	.75-.99	TG-75-72"	5000 LBS.
1303-014	1.00-1.49	TG-100-24"	6400 LBS.
1303-015	1.00-1.49	TG-100-36"	6400 LBS.
1303-016	1.00-1.49	TG-100-48"	6400 LBS.
1303-017	1.00-1.49	TG-100-60"	6400 LBS.
1303-018	1.00-1.49	TG-100-72"	6400 LBS.
1303-019	1.50-1.99	TG-150-36"	9700 LBS.
1303-020	1.50-1.99	TG-150-48"	9700 LBS.
1303-021	1.50-1.99	TG-150-60"	9700 LBS.
1303-022	1.50-1.99	TG-150-72"	9700 LBS.

DOUBLE WEAVE

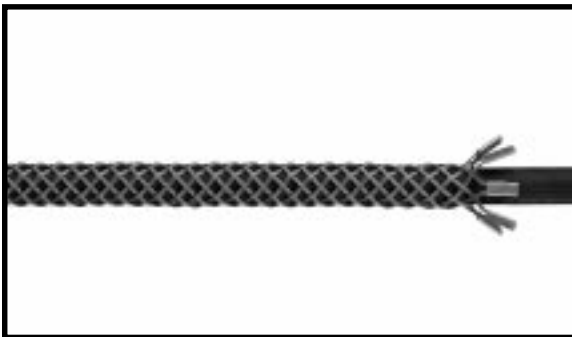

1304-001	.37-.49	TGD-37-18"	3500 LBS.
1304-002	.50-.62	TGD-50-18"	3500 LBS.
1304-003	.50-.62	TGD-50-24"	3500 LBS.
1304-004	.62-.74	TGD-62-18"	4400 LBS.
1304-005	.62-.74	TGD-62-24"	4400 LBS.
1304-006	.62-.74	TGD-62-36"	4400 LBS.
1304-007	.75-.99	TGD-75-24"	7500 LBS.
1304-008	.75-.99	TGD-75-36"	7500 LBS.
1304-009	.75-.99	TGD-75-48"	7500 LBS.
1304-010	.75-.99	TGD-75-60"	7500 LBS.
1304-011	.75-.99	TGD-75-72"	7500 LBS.
1304-012	1.00-1.49	TGD-100-24"	10000 LBS.
1304-013	1.00-1.49	TGD-100-36"	10000 LBS.
1304-014	1.00-1.49	TGD-100-48"	10000 LBS.
1304-015	1.00-1.49	TGD-100-60"	10000 LBS.
1304-016	1.00-1.49	TGD-100-72"	10000 LBS.
1304-017	1.50-1.99	TGD-150-36"	16000 LBS.
1304-018	1.50-1.99	TGD-150-48"	16000 LBS.
1304-019	1.50-1.99	TGD-150-60"	16000 LBS.
1304-020	1.50-1.99	TGD-150-72"	16000 LBS.

CAUTION: NEVER USE GRIPS TO APPROX. BREAKING STRENGTH. REFER TO PG B FOR SAFETY AND WORKING LOAD FACTORS.

AMTEC STRAIN RELIEF

AMTEC STRAIN RELIEF GRIPS ARE WIDE RANGE MESH CONSTRUCTION WITH SINGLE WEAVE, GALVANIZED STEEL MESH. THE ONE PIECE DESIGN IS EASILY INSTALLED. AMTEC STRAIN RELIEF GRIPS ARE USED TO CONNECT FLEXIBLE CORD OR BUS DROP CABLE TO ELECTRICAL ENCLOSURES, ALSO PREVENTS CORD OR CABLE PULL OUT. INSULATING BUSHING AVAILABLE FOR NON-INSULATED ALUMINUM FITTINGS. AVAILABLE WITH LOCKNUT AND PVC GASKET FOR A DIRT AND DUST FREE SEAL. DRY LOCATIONS ONLY.

SR SERIES Non-Insulated Wide Range Strain Relief

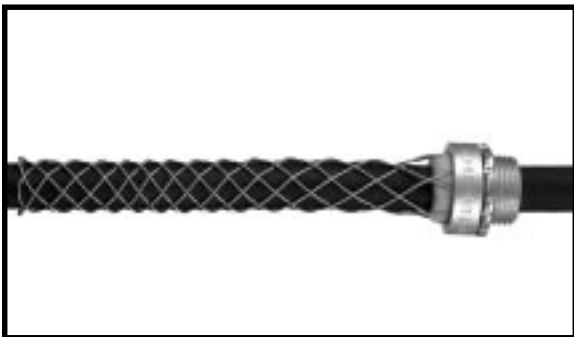

PART NUMBER	DIA. RA.	DESCRIPTION	THREAD SIZE NPT (INCHES)	LENGTH @ NOM DIA. (IN.)
7303-001	.24-.32	SR-022	1/2	3 1/4
7303-002	.32-.43	SR-030	1/2	3 3/4
7303-003	.43-.54	SR-040	1/2	4 3/4
7303-004	.54-.73	SR-052	3/4	6 1/2
7303-005	.73-.97	SR-070	1	7
7303-006	.97-1.25	SR-094	1 1/4	9



LISTED 4D55

DRY LOCATION ONLY

SRP SERIES Insulated Wide Range Strain Relief with Insulating Bushing

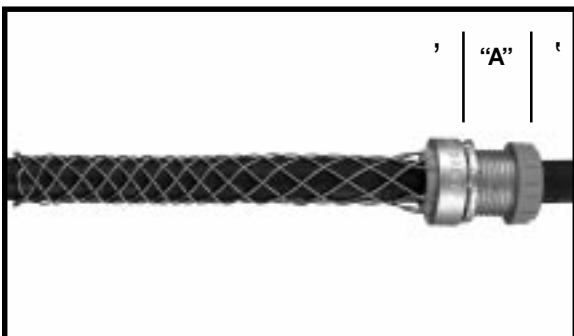

PART NUMBER	DIA. RA.	DESC.	MESH THREAD SIZE (IN)	LENGTH NOM DIA	DIM. A (INCHES)
7303-008	.24-.32	SRP-022	1/2 N.P.S.	3 1/4	1
7303-009	.32-.43	SRP-030	1/2 N.P.S.	3 3/4	1
7303-010	.43-.54	SRP-040	1/2 N.P.S.	4 3/4	1
7303-011	.54-.73	SRP-052	3/4 N.P.S.	6 1/2	1
7303-012	.73-.97	SRP-070	1 N.P.S.	7	1 3/16
7303-013	.97-1.25	SRP-094	1 1/4 N.P.S.	9	1 3/16
7303-014	1.25-1.50	SRP-120	1 1/2 N.P.T.	11 3/4	1 3/16
7303-015	1.50-1.70	SRP-140	2 N.P.T.	13 1/4	1 3/8
7303-016	1.70-2.00	SRP-162	2 1/2 N.P.T.	13 1/2	1 1/2
7303-017	2.00-2.45	SRP-200	2 1/2 N.P.T.	13 3/4	1 1/2



LISTED 4D55

DRY LOCATION ONLY

CAUTION: NEVER USE GRIPS TO APPROX. BREAKING STRENGTH. REFER TO PG B FOR SAFETY AND WORKING LOAD FACTORS.

AMTEC BUS DROP GRIPS

AMTEC BUS DROP GRIPS ARE MADE OF HIGH STRENGTH GALVANIZED STEEL STRAND. STAINLESS IS AVAILABLE UPON REQUEST. AMTEC BUS DROP GRIPS ARE EASILY INSTALLED AND ABSORB TENSION, VIBRATION AND PULL WITH NO DAMAGE. THEY SUPPORT FLEXIBLE CORD OR BUS DROP CABLE AT BUS DUCT OR INDUSTRIAL AREAS. SINGLE EYE CAN BE USED WITH SPRINGS BY DISASSEMBLING DRAW BAR FROM COIL, PLACING THROUGH EYE AND REPLACING DRAWBAR. HOOK EYES AVAILABLE PLEASE CONSULT FACTORY.

SINGLE EYE, WIDE RANGE

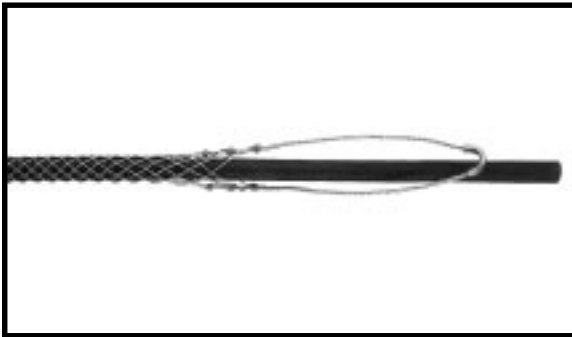

PART NUMBER	DIA. RA.	DESCRIPTION	APPROX. BREAKING STRENGTH	LENGTH E* M
7304-001	.22-.32	BD-022	350 LBS.	3 3 1/2
7304-002	.30-.43	BD-030	450 LBS.	4 4
7304-003	.41-.56	BD-041	550 LBS.	6 4 3/4
7304-004	.53-.73	BD-053	1000 LBS.	7 6
7304-005	.70-.85	BD-070	1400 LBS.	7 6 3/4
7304-006	.82-1.00	BD-082	1400 LBS.	8 8
7304-007	.96-1.25	BD-096	1500 LBS.	9 9 1/2



LISTED 4D55

DRY LOCATION ONLY

UNIVERSAL BAIL, WIDE RANGE

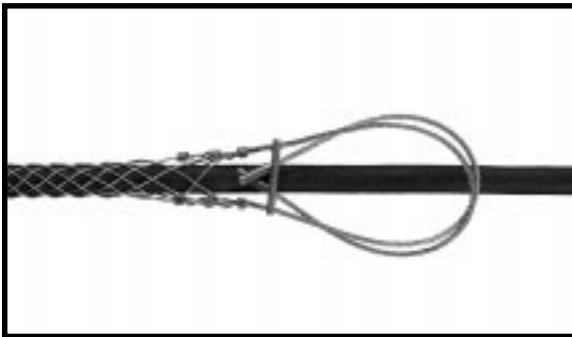

7304-009	.22-.32	BD-022-UB	350 LBS.	9 3 1/2
7304-010	.30-.43	BD-030-UB	450 LBS.	10 4
7304-011	.41-.56	BD-041-UB	550 LBS.	12 4 3/4
7304-012	.53-.73	BD-053-UB	1000 LBS.	13 6
7304-013	.70-.85	BD-070-UB	1400 LBS.	13 6 3/4
7304-014	.82-1.00	BD-082-UB	1400 LBS.	14 8
7304-015	.96-1.25	BD-096-UB	1500 LBS.	15 9 1/2



LISTED 4D55

DRY LOCATION ONLY

BUS DROP SAFETY SPRINGS

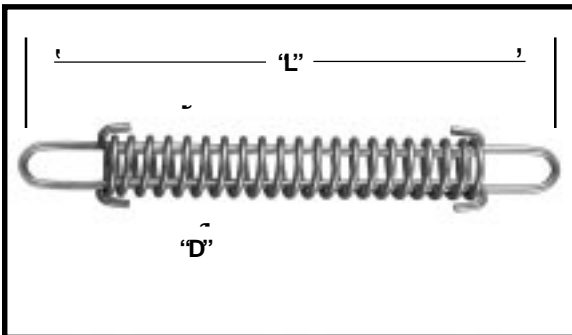

PART NUMBER	MAXIMUM DEFLECTION	DESCRIPTION	APPROX. BREAKING STRENGTH	LENGTH (NO LOAD) L D
203-02-001	2 1/8 @40 LBS.	40 LB. SPRING	600 LBS.	8 1/4 3/4
203-02-002	3 1/8 @80 LBS.	80 LB. SPRING	850 LBS.	8 1/4 1

E = EYE LENGTH M = MESH LENGTH AT NOMINAL DIAMETER (INCHES)

*DIM WITH BAILE FULLY EXTENDED

CAUTION: NEVER USE GRIPS TO APPROX. BREAKING STRENGTH. REFER TO PG B FOR SAFETY AND WORKING LOAD FACTORS.

AMTEC DELUXE CORD GRIPS

AMTEC DELUXE CORD GRIPS ARE USED WHENEVER CABLE OR CORD MUST WITHSTAND EXTREME APPLICATIONS AND ENVIRONMENTAL CONDITIONS. WIDELY USED WITH SWITCH BOXES, POWER DUCT CUT-OUT, DROP STATIONS, POWER HAND TOOLS, MOVING PARTS OF MACHINERY, PUMPS, COMPRESSORS AND BUS DROP INSTALLATIONS. ENDLESS WEAVE PROVIDES SMOOTH CABLE-HUGGING ENDS FOR CONSTRUCTION FREE INSTALLATION.



THREAD SIZE N.P.T.	GRIP DIAM. RANGE INCHES	MALE THREAD DESCRIPT.	90° MALE THREAD DESCRIPT.	45° MALE THREAD DESCRIPT.	FEMALE THREAD DESCRIPT.
3/8"	.18-.25 .25-.37 .37-.43	DCG-25 F1 DCG-37 F1 DCG-43 F1	DCG-25 F1 90 DCG-37 F1 90 DCG-43 F1 90	DCG-25 F1 45 DCG-37 F1 45 DCG-43 F1 45	DCG-25 F1-F DCG-37 F1-F DCG-43 F1-F
1/2"	.18-.25 .25-.37 .37-.43 .43-.50 .50-.62	DCG-25 F2 DCG-37 F2 DCG-43 F2 DCG-50 F2 DCG-62 F2	DCG-25 F2 90 DCG-37 F2 90 DCG-43 F2 90 DCG-50 F2 90 DCG-62 F2 90	DCG-25 F2 45 DCG-37 F2 45 DCG-43 F2 45 DCG-50 F2 45 DCG-62 F2 45	DCG-25 F2-F DCG-37 F2-F DCG-43 F2-F DCG-50 F2-F DCG-62 F2-F
3/4"	.18-.25 .25-.37 .37-.50 .50-.62 .62-.75	DCG-25 F3 DCG-37 F3 DCG-50 F3 DCG-62 F3 DCG-75 F3	DCG-25 F3 90 DCG-37 F3 90 DCG-50 F3 90 DCG-62 F3 90 DCG-75 F3 90	DCG-25 F3 45 DCG-37 F3 45 DCG-50 F3 45 DCG-62 F3 45 DCG-75 F3 45	DCG-25 F3-F DCG-37 F3-F DCG-50 F3-F DCG-62 F3-F DCG-75 F3-F
1"	.37-.50 .50-.62 .62-.75 .75-.87 .87-1.00	DCG-50 F4 DCG-62 F4 DCG-75 F4 DCG-87 F4 DCG-100 F4	DCG-50 F4 90 DCG-62 F4 90 DCG-75 F4 90 DCG-87 F4 90 DCG-100 F4 90	DCG-50 F4 45 DCG-62 F4 45 DCG-75 F4 45 DCG-87 F4 45 DCG-100 F4 45	DCG-50 F4-F DCG-62 F4-F DCG-75 F4-F DCG-87 F4-F DCG-100 F4-F
1 1/4"	.75-.87 .87-1.00 1.00-1.125 1.12-1.25 1.25-1.37	DCG-87 F5 DCG-100 F5 DCG-112 F5 DCG-125 F5 DCG-137 F5	DCG-87 F5 90 DCG-100 F5 90 DCG-112 F5 90 DCG-125 F5 90 DCG-137 F5 90	DCG-87 F5 45 DCG-100 F5 45 DCG-112 F5 45 DCG-125 F5 45 DCG-137 F5 45	DCG-87 F5-F DCG-100 F5-F DCG-112 F5-F DCG-125 F5-F DCG-137 F5-F

AMTEC DELUXE CORD GRIPS



THREAD SIZE N.P.T.	GRIP DIAM. RANGE INCHES	MALE THREAD DESCRIP.	90° MALE THREAD DESCRIP.	45° MALE THREAD DESCRIP.	FEMALE THREAD DESCRIP.
1 1/2"	.75-.87 .87-1.00 1.00-1.125 1.125-1.25 1.25-1.37 1.37-1.43	DCG-87 F6 DCG-100 F6 DCG-112 F6 DCG-125 F6 DCG-137 F6 DCG-143 F6	DCG-87 F6 90 DCG-100 F6 90 DCG-112 F6 90 DCG-125 F6 90 DCG-137 F6 90 DCG-143 F6 90	DCG-87 F6 45 DCG-100 F6 45 DCG-112 F6 45 DCG-125 F6 45 DCG-137 F6 45 DCG-143 F6 45	DCG-87 F6-F DCG-100 F6-F DCG-112 F6-F DCG-125 F6-F DCG-137 F6-F DCG-143 F6-F
2"	1.25-1.375 1.37-1.437 1.43-1.562 1.56-1.687 1.68-1.812 1.75-1.875 1.81-1.937 1.937-2.062	DCG-137 F7 DCG-143 F7 DCG-156 F7 DCG-168 F7 DCG-181 F7 DCG-187 F7 DCG-193 F7 DCG-206 F7	DCG-137 F7 90 DCG-143 F7 90 DCG-156 F7 90 DCG-168 F7 90 DCG-181 F7 90 DCG-187 F7 90 DCG-193 F7 90 DCG-206 F7 90		
2 1/2"	1.687-1.812 1.812-1.937 1.937-2.062 2.062-2.187 2.187-2.312 2.312-2.437	DCG-181 F8 DCG-193 F8 DCG-206 F8 DCG-218 F8 DCG-231 F8 DCG-243 F8			
3"	1.687-1.812 1.812-1.937 1.937-2.062 2.062-2.187 2.187-2.312 2.312-2.437 2.437-2.625 2.625-2.812 2.812-3.000	DCG-181 F9 DCG-193 F9 DCG-206 F9 DCG-218 F9 DCG-231 F9 DCG-243 F9 DCG-262 F9 DCG-281 F9 DCG-300 F9			

AMTEC I - GRIPS

AMTEC I-GRIPS ARE EASY TO ATTACH, WILL CONTROL CABLE-ARC-OF-BEND AND PROVIDE HEAVY DUTY STRAIN RELIEF. AMTEC I-GRIPS ARE MADE OF HIGH STRENGTH GALVANIZED STEEL STRAND AND ARE RECOMMENDED FOR INDOOR USE ONLY.

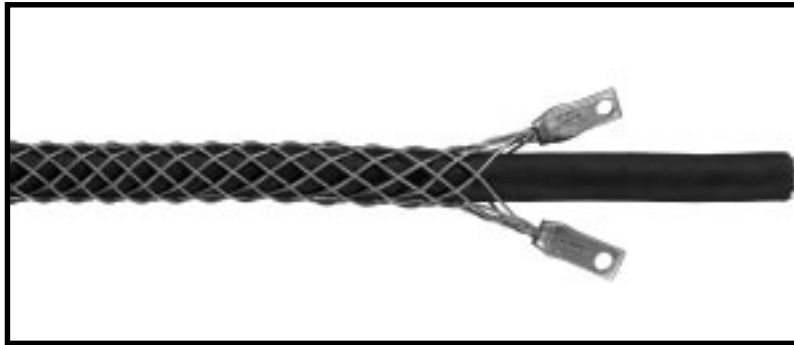

I - GRIPS

CATALOG NUMBER	DESCRIPTION	CABLE DIAMETER RANGE INCHES	E	M
7310-001	I - 030	.30-.43	1.25	4
7310-002	I - 040	.40-.56	1.25	4-3/4
7310-003	I - 052	.52-.73	1.50	6
7310-004	I - 070	.70-.85	1.50	6-1/2
7310-005	I - 082	.82-1.00	1.50	8
7310-006	I - 094	.94-1.25	1.50	10

E = EYE LENGTH M = MESH LENGTH AT NOMINAL DIAMETER (INCHES)

CAUTION: NEVER USE GRIPS TO APPROX. BREAKING STRENGTH. REFER TO PG B FOR SAFETY AND WORKING LOAD FACTORS.

AMTEC ADAPTERS

AMTEC ADAPTERS CAN BE USED WHEREVER STRAIGHT THREAD CONNECTORS AND AN-MS MULTIPLE PIN CONNECTORS ARE SUBJECTED TO PULL TENSIONS, FLEXING, BENDING, TWISTING AND VIBRATION, ALLOWING THE USE OF AMTEC GRIPS. ELECTRICAL CONSOLES, MOBILE EQUIPMENT OR ELECTRICAL TERMINATIONS WHERE PLUGS ARE USED FOR CONNECTING AND DISCONNECTING ELECTRICAL CIRCUITS REQUIRE ADDITIONAL PROTECTION.



ADAPTER AND GRIP N.P.T. THREAD SIZE "B" INCHES	AN-MS CONNECTOR SIZE (no. stamped on connector shell)	AN-MS CABLE CLAMP NUMBER (no. stamped on clamp shell)	THREAD SIZE "A"	ADAPTER PART NUMBER
3/8	8S, 10S 10SL, 12, 12S 14, 14S	3057-3	1/2 X 28	9104-1000
		3057-4	5/8 X 24	9104-1001
		3057-6	3/4 X 20	9104-1002
1/2	14, 14S 16, 16S 18	3057-6	3/4 X 20	9104-1003
		3057-8	7/8 X 20	9104-1004
		3057-10	1 X 20	9104-1006
3/4	16, 16S 18 20, 22	3057-8	7/8 X 20	9104-1005
		3057-10	1 X 20	9104-1007
		3057-12	1-3/16 X 18	9104-1008
1	20, 22 24, 28 32 36	3057-12	1-3/16 X 18	9104-1009
		3057-16	1-7/16 X 18	9104-1010
		3057-20	1-3/4 X 18	9104-1012
		3057-24	2 X 18	9104-1015
1 1/4	24, 28 32 36	3057-16	1-7/16 X 18	9104-1011
		3057-20	1- 3/4 X 18	9104-1013
		3057-24	2 X 18	9104-1016
1 1/2	32 36 40 44 48	3057-20	1- 3/4 X 18	9104-1014
		3057-24	2 X 18	9104-1017
		3057-28	2- 1/4 X 16	9104-1019
		3057-32	2- 1/2 X 16	9104-1021
		3057-40	3 X 16	9104-1023
2	36 40 44 48	3057-24	2 X 18	9104-1018
		3057-28	2-1/4 X 16	9104-1020
		3057-32	2-1/2 X 16	9104-1022
		3057-40	3 X 16	9104-1024

AMTEC CONNECTOR GRIPS

CUSTOM DESIGNED

POWER & CONTROL CABLE STRAIN RELIEF



- USE WITH ALL CONNECTOR TYPES, CORD SETS AND ASSEMBLIES TO REMOVE STRAIN, VIBRATION, FLEXURE OR MOTION.
- CUSTOM DESIGNED TO MATE WITH SPECIALLY SHAPED OR SIZED ELECTRICAL CONNECTORS.
- ELIMINATES DIRECT TENSION FROM TERMINAL, THUS REMOVING STRAIN FROM CRITICAL ELECTRICAL CONNECTIONS.
- CONNECTOR GRIPS EXTEND THE LIFE OF ELECTRICAL SYSTEMS AND ADD SAFETY.
- STAINLESS STEEL GRIPS ARE CORROSION FREE.
- ELIMINATE RIGID FATIGUE POINTS.
- PREVENTS PULL TENSION, THUS REDUCING CABLE PULL OUT AND SYSTEM DOWN TIME.
- CAN BE ADAPTED TO ANY CONNECTOR INCLUDING FIBER OPTIC CABLE.
- COLLARS AVAILABLE IN ALUMINUM OR STAINLESS STEEL.
- MULTI-WEAVE GRIP FEATURE CONTROLS UNIFORM ARC OF BEND CONTROL.

CAUTION: ALWAYS REFER TO SAFETY AND WORKING LOAD FACTORS.